

## equip 19" Flat Pack Cabinet

This wall-mounted cabinet represents the conception of „flat pack“, which means a demountable cabinet that is supplied disassembled.



### Overview

This 19" wall-mounted cabinet with IP 30 protection offers a high quality processing and the newest technologies to ensure a long operating life time. This cabinet is supplied only with a glass door and a lock. The hinge system enables almost 180° wide opening of the door. The door can be easily removed and mounted for a change of the door opening direction. The vertical 19" rails (1x pair) can be adjusted freely in any depth of the cabinet. This simplifies the mounting of the devices and the configuration of connecting cables.

### Flat-Pack Concept

Reduce costs of transportation and storage. Together with a unique construction, it contributes to the attractive price while keeping all functional characteristics.

### Monting

Thanks to the unique construction, the assembly procedure of equip 19" flat pack cabinet takes only few minutes and it does not almost require any tools (Torx T25).

## Breakout-type Blanking Panels

The cable openings are covered with breakout-type blanking panels are ready in the top, bottom and rear part of the cabinet.

### Key Features

- 19" flat pack box
- demountable, compact packing measures
- easy for shipping
- plastic pins are used to join all parts of the cabinet
- the assembly procedure takes only a couple of minutes
- the maximal loading capacity is up to 25kgs
- with lockable glass door
- door for left or right opening
- break out cable entries are located in the top and bottom as well as in the middle of the back side
- all metallic parts of the cabinet are mutually earth connected
- available in RAL 7035 light grey and RAL 9005 black

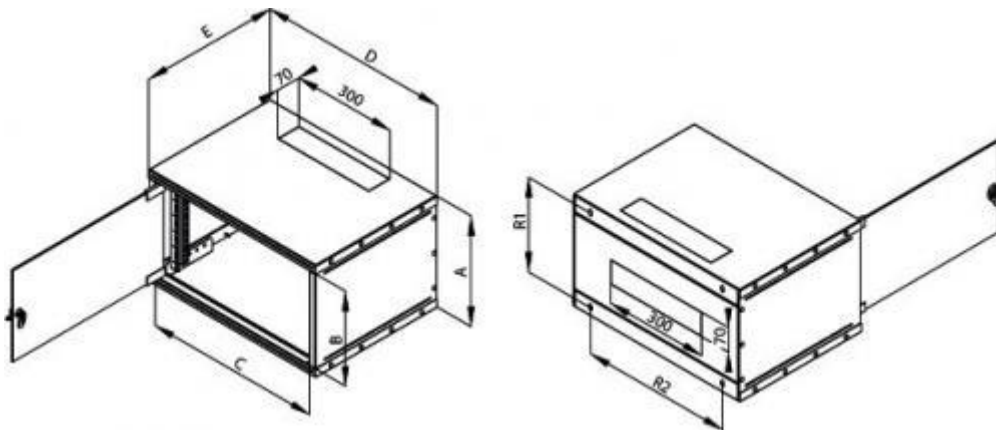

equip Article No		A	B	C	D	E	R1	R2	Weight gross kg	Weight net kg	Maximal recommended load kg
grey	black	mm									
901004	991004	230	180	505	550	400	180	435	11,2	11	
901006	991006	320	270	505	550	400	270	435	21,7	21,4	
901009	991009	463	412	505	550	400	412	435	25,4	25,1	
901012	991012	580	530	505	550	400	530	435	29,1	28,7	

**Material**

tempered safety glass 5 mm  
sheet steel

**Order-Information**

equip 19" Flat Pack Cabinet

**Packaging**

2x top cover AS4, 2x side panel (04U, 06U, 09U), 1x back panel (04U, 06U, 09U)

2x vertical rail (04U, 06U, 09U), 1x fully glass door (04U, 06U, 09U)

1x lock (2x plastic washer, 1x assembled lock), 2x hinges, 1x small label

1x nut M8 (DIN 934), 3x nut M5 with serrated washer

2x serrated washer 8,4 (Zn, DIN 6798 A/VZ)

4x self-threading screw (DIN7500C Zn., Torx M5x12)

37x plastic pin

3x earthing cable 27ZK-27k M5 (staple-connector)

1x earthing cable 32: M5 (staple-staple)

2x key - front door